



# Storage Solutions Safes

## SECURITY FEATURES

- Multi point locking bars
- Heavy duty steel construction
- 6mm door, 5mm body
- High quality UL listed digital keypad and locks
- Anti-tamper re-locking devices

## PRODUCT SPECIFICATIONS

Model	EXTERNAL (MM)			INTERNAL (MM)			Weight (kg)	Shelves (pc)	REC. RETAIL PRICE \$	
	H	W	D	H	W	D			excl.GST	incl.GST (10%)
GS70E	750	570	420	740	540	350	99	2		
SG60	1500	760	505	1490	750	400	215	3		
SC1800-1	1800	600	450	1785	580	365	250	4		
SC1800-2	1800	900	500	1785	885	415	316	4		

DEPTH MEASUREMENT DOES NOT INCLUDE THE HANDLE, KEYPAD OR HINGES. PLEASE ALLOW 50MM.  
 Due to Guardall constantly striving to deliver better products; sizes and colours may vary slightly.

This Guardall range is the perfect solution for the storage of bulky items that need to be stored with security in mind. For example: Supermarkets storing cigarettes and other valuable merchandise, tradesman storing expensive tools.

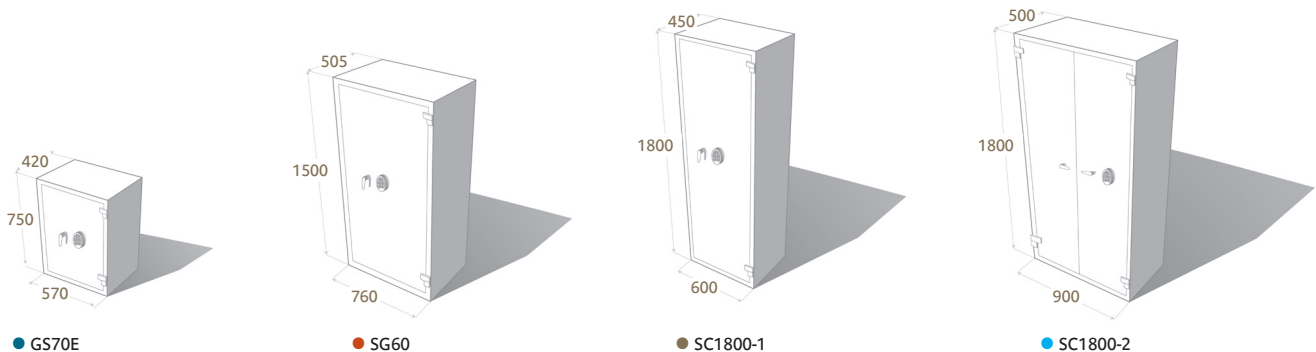

● GS70E

● SG60

● SC1800-1

● SC1800-2